

# SIEMENS

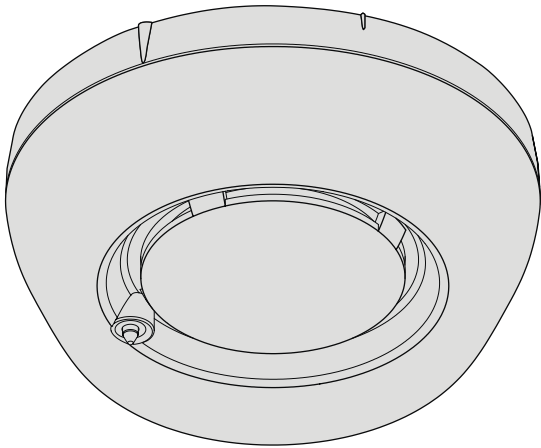

## FDS221

### Alarm sounder

### Technical Manual

## Legal notice

Technical specifications and availability subject to change without notice.

© 2004-2013 Copyright by Siemens Switzerland Ltd

Transmittal, reproduction, dissemination and/or editing of this document as well as utilization of its contents and communication thereof to others without express authorization are prohibited. Offenders will be held liable for payment of damages. All rights created by patent grant or registration of a utility model or design patent are reserved.

Issued by:

Siemens Switzerland Ltd.

Infrastructure & Cities Sector

Building Technologies Division

International Headquarters

Gubelstrasse 22

CH-6301 Zug

Tel. +41 41 724-2424

[www.siemens.com/buildingtechnologies](http://www.siemens.com/buildingtechnologies)

Edition: 2013-10-18

Document ID: 008109\_k\_en\_--

# Table of contents

<b>1</b>	<b>About this document</b> .....	<b>5</b>
1.1	Applicable documents.....	7
1.2	Download center.....	7
1.3	Technical terms.....	7
1.4	History of changes.....	8
<b>2</b>	<b>Safety</b> .....	<b>10</b>
2.1	Safety instructions.....	10
2.2	Safety regulations for the method of operation.....	12
2.3	Standards and directives complied with.....	14
2.4	Release Notes.....	14
<b>3</b>	<b>Structure and function</b> .....	<b>15</b>
3.1	Overview.....	15
3.1.1	Details for ordering.....	16
3.1.2	Product version ES.....	16
3.2	Function.....	17
3.2.1	Escalation levels and sound levels.....	17
3.2.2	Line separator.....	17
3.2.3	Interface to service devices.....	17
3.2.4	Diagnosis levels.....	18
3.2.5	Behaviour in degraded mode.....	19
3.3	Accessories.....	19
3.3.1	Addressable detector base FDB221/FDB221-AA.....	19
3.3.2	Flat, addressable detector base FDB222.....	20
3.3.3	Sealing kit FDBZ295.....	20
3.3.4	Base attachment FDB291.....	20
3.3.5	Base attachment humid FDB293.....	21
3.3.6	Base attachment wet FDB295.....	21
3.3.7	Protective cage DBZ1194.....	21
3.3.8	Dummy detector FDX291.....	22
3.3.9	Designation plate FDBZ291.....	22
3.3.10	Designation plate DBZ1193A.....	22
3.3.11	Detector locking device FDBZ293.....	23
3.3.12	Micro terminal DBZ1190-AA.....	23
3.3.13	Connection terminal DBZ1190-AB.....	23
3.3.14	M20 x 1.5 metal cable gland.....	23
<b>4</b>	<b>Project engineering</b> .....	<b>24</b>
4.1	Compatibility.....	24
4.2	Ranges of application.....	24
4.3	Installation site.....	25
4.4	Restrictions.....	25

4.5	Configuration.....	25
4.5.1	Alarm sounder with ES <30.....	26
4.5.2	Alarm sounder with ES ≥30.....	27
<b>5</b>	<b>Mounting / Installation.....</b>	<b>28</b>
5.1	Base attachment FDB291.....	30
5.2	Base attachment humid FDB293.....	31
5.3	Sealing kit FDBZ295.....	32
5.4	Designation plate FDBZ291.....	34
5.5	Designation plate DBZ1193A.....	35
5.6	Detector locking device FDBZ293.....	36
<b>6</b>	<b>Commissioning.....</b>	<b>37</b>
<b>7</b>	<b>Maintenance / Repair.....</b>	<b>38</b>
7.1	Status retrieval.....	38
7.2	Function check.....	38
<b>8</b>	<b>Specifications.....</b>	<b>39</b>
8.1	Technical data.....	39
8.2	Dimensions.....	41
8.3	Environmental compatibility and disposal.....	41
<b>9</b>	<b>Annex technical data.....</b>	<b>42</b>
9.1	Tones and sound levels of the alarm sounder (DC 32 V).....	42
<b>Index</b>	.....	<b>45</b>

# 1 About this document

## Goal and purpose

This document contains all necessary information on the FDS221 alarm sounder. Following the instructions consistently will ensure that the product can be used safely and without any problems.

## Target groups

The information in this document is intended for the following target groups:

Target group	Activity	Qualification
Product Manager	<ul style="list-style-type: none"> <li>Is responsible for information passing between the manufacturer and regional company.</li> <li>Coordinates the flow of information between the individual groups of people involved in a project.</li> </ul>	<ul style="list-style-type: none"> <li>Has obtained suitable specialist training for the function and for the products.</li> <li>Has attended the training courses for Product Managers.</li> </ul>
Project Manager	<ul style="list-style-type: none"> <li>Coordinates the deployment of all persons and resources involved in the project according to schedule.</li> <li>Provides the information required to run the project.</li> </ul>	<ul style="list-style-type: none"> <li>Has obtained suitable specialist training for the function and for the products.</li> <li>Has attended the training courses for Project Managers.</li> </ul>
Installation personnel	<ul style="list-style-type: none"> <li>Assembles and installs the product components at the place of installation.</li> <li>Carries out a performance check following installation.</li> </ul>	<ul style="list-style-type: none"> <li>Has received specialist training in the area of building installation technology or electrical installations.</li> </ul>
Commissioning personnel	<ul style="list-style-type: none"> <li>Configure the product at the place of installation according to customer-specific requirements.</li> <li>Check the product operability and release the product for use by the operator.</li> <li>Searches for and corrects malfunctions.</li> </ul>	<ul style="list-style-type: none"> <li>Has obtained suitable specialist training for the function and for the products.</li> <li>Has attended the training courses for commissioning personnel.</li> </ul>
Maintenance personnel	<ul style="list-style-type: none"> <li>Carries out all maintenance work.</li> <li>Checks that the products are in perfect working order.</li> <li>Searches for and corrects malfunctions.</li> </ul>	<ul style="list-style-type: none"> <li>Has obtained suitable specialist training for the function and for the products.</li> </ul>

## Reference document and source language

- The source language of this document is German (de).
- The reference version of this document is the international version in English. The international version is not localized.

The reference document has the following designation:

ID\_x\_en\_--

x = version, en = English, -- = international

## Document identification

The document ID is structured as follows:

ID code	Examples
ID_ModificationIndex_Language_COUNTRY -- = multilingual or international	A6V10215123_a_de_DE A6V10215123_a_en_-- A6V10315123_a_--_--

## Date format

The date format in the document corresponds to the recommendation of international standard ISO 8601 (format YYYY-MM-DD).

## Conventions for text marking

### Markups

Special markups are shown in this document as follows:

▷	Requirement for a behavior instruction
1. 2.	Behavior instruction with at least two operation sequences
–	Version, option, or detailed information for a behavior instruction
⇒	Intermediate result of a behavior instruction
⇨	End result of a behavior instruction
●	Numbered lists and behavior instructions with an operation sequence
[→ X]	Reference to a page number
'Text'	Quotation, reproduced identically
<Key>	Identification of keys

### Supplementary information and tips



The 'i' symbol identifies supplementary information and tips for an easier way of working.

## 1.1 Applicable documents

Document ID	Title
007026	Data Sheet Sounder bases FDSB291, FDSB292, Alarm sounders FDS221-R, FDS221-W
007227	Operation Detector exchanger and tester FDUD292
008168	Installation Alarm sounder FDS221
008331	List of compatibility (for 'Sinteso™' product line)
009718	Operation Intelligent detector tester FDUD293
A6V10208532	Installation Sealing element FDBZ295
A6V10208546	Installation Detector base FDB20x/FDB201-AA, FDB22x/FDB221-AA, Base attachment FDB291, Detector designation plate FDBZ291, Dummy detector FDX291
A6V10208550	Installation Base attachment humid FDB293
A6V10208552	Installation Detector locking device FDBZ293
A6V10229261	List of compatibility (for 'Cerberus PRO™' product line)
A6V10331076	Installation Base attachment wet FDB295, Detector designation plate DBZ1193A, Protective cage DBZ1194, EMC-protective cage FDBZ294

Please also observe the documentation for your fire detection system.

## 1.2 Download center

You can download various types of documents, such as data sheets, installation instructions, and license texts via the following Internet address:

<http://siemens.com/bt/download>

- Enter the document ID in the 'Find by keywords' input box.



### **NOTICE**

You will also find information about search variants and links to mobile applications (apps) for various systems on the home page.

## 1.3 Technical terms

Term	Explanation
AI	Alarm indicator
FDnet/C-NET	Addressable detector line
ES	Product version
MC link	Maintenance and commissioning link (proximity interface)

## 1.4 History of changes

The reference document's version applies to all languages into which the reference document is translated.



The first edition of a language version or a country variant may, for example, be version 'd' instead of 'a' if the reference document is already this version.

The table below shows this document's history of changes:

Modification index	Edition date	Brief description
k	2013-10-18	Data sheet in 'Applicable documents' chapter added; sound levels in the annex changed; change to date format in line with ISO 8601 specifications (yyyy-mm-dd format); 'Download center' chapter added; base attachment wet FDB295 added as accessory; term 'sound intensity' changed to 'sound level'
j	2010-05	Document fully revised
i	2009-07	Editorial changes made
h	2008-03	Sound intensities in the annex changed FDB222 detector base added Dummy detector newly added Drawings for pulse pattern adapted
g	2007-09	Diagnosis levels changed Escalation levels changed (chapter 3.2.1)
f	2007-07	Protection categories (IP) changed
e	2007-07	Chapter 4.5.2 revised Chapter 8.1: Ambient conditions, Air humidity Chapter 8.1: Line separator added Chapter 8.1: Standards added Chapter 8.4: Annex technical data added
d	2006-12	ES (product version) listed under Technical terms. Base attachment FDB291 IP42 or IP43; dependent on mounting and connection. Base attachment humid FDB293 IP54.
c	2006-09	Alarm sounder with product version (ES) $\geq 30$ included Address Technical data revised.
b	2005-01	Name of division
a	2004-04	First edition



The table below shows the published language versions with the corresponding modification index:

Modification index	en_--	de_--	fr_--	it_--	es_--
k	X	X	X	X	X
j	X	X	X	X	X
i	X	X	-	-	-
h	X	X	-	-	-
g	X	X	-	-	-
f	X	X	-	-	-
e	X	X	-	-	-
d	X	X	-	-	-
c	X	X	-	-	-
b	X	X	X	X	X
a	X	X	X	X	X

X = published

- = no publication with this modification index

## 2 Safety

### 2.1 Safety instructions

The safety notices must be observed in order to protect people and property.

The safety notices in this document contain the following elements:

- Symbol for danger
- Signal word
- Nature and origin of the danger
- Consequences if the danger occurs
- Measures or prohibitions for danger avoidance

#### Symbol for danger



This is the symbol for danger. It warns of **risks of injury**.

Follow all measures identified by this symbol to avoid injury or death.

#### Additional danger symbols

These symbols indicate general dangers, the type of danger or possible consequences, measures and prohibitions, examples of which are shown in the following table:



General danger



Voltage/electric shock



Battery



Explosive atmosphere



Laser light



Heat



#### Signal word

The signal word classifies the danger as defined in the following table:

Signal word	Danger level
<b>DANGER</b>	<b>DANGER</b> identifies a dangerous situation, which <b>will result directly in death or serious injury</b> if you do not avoid this situation.
<b>WARNING</b>	<b>WARNING</b> identifies a dangerous situation, which <b>may result in death or serious injury</b> if you do not avoid this situation.
<b>CAUTION</b>	<b>CAUTION</b> identifies a dangerous situation, which <b>could result in slight to moderately serious injury</b> if you do not avoid this situation.
<i>NOTICE</i>	<i>NOTICE</i> identifies possible damage to property that may result from non-observance.

### How risk of injury is presented

Information about the risk of injury is shown as follows:

	 <b>WARNING</b>
	<p><b>Nature and origin of the danger</b> Consequences if the danger occurs</p> <ul style="list-style-type: none"> <li>• Measures / prohibitions for danger avoidance</li> </ul>

### How possible damage to property is presented

Information about possible damage to property is shown as follows:

	<b>NOTICE</b>
	<p><b>Nature and origin of the danger</b> Consequences if the danger occurs</p> <ul style="list-style-type: none"> <li>• Measures / prohibitions for danger avoidance</li> </ul>

## 2.2 Safety regulations for the method of operation

### National standards, regulations and legislation

Siemens products are developed and produced in compliance with the relevant European and international safety standards. Should additional national or local safety standards or legislation concerning the planning, assembly, installation, operation or disposal of the product apply at the place of operation, then these must also be taken into account together with the safety regulations in the product documentation.

### Electrical installations

	<b>▲ WARNING</b>
	<p><b>Electrical voltage</b> Electric shock</p> <ul style="list-style-type: none"> <li>● Work on electrical installations may only be carried out by qualified electricians or by instructed persons working under the guidance and supervision of a qualified electrician, in accordance with the electrotechnical regulations.</li> </ul>

- Wherever possible disconnect products from the power supply when carrying out commissioning, maintenance or repair work on them.
- Lock volt-free areas to prevent them being switched back on again by mistake.
- Label the connection terminals with external external voltage using a 'DANGER External voltage' sign.
- Route mains connections to products separately and fuse them with their own, clearly marked fuse.
- Fit an easily accessible disconnecting device in accordance with IEC 60950-1 outside the installation.
- Produce earthing as stated in local safety regulations.

### Assembly, installation, commissioning and maintenance

- If you require tools such as a ladder, these must be safe and must be intended for the work in hand.
- When starting the fire control panel ensure that unstable conditions cannot arise.
- Ensure that all points listed in the 'Testing the product operability' section below are observed.
- You may only set controls to normal function when the product operability has been completely tested and the system has been handed over to the customer.

### Testing the product operability

- Prevent the remote transmission from triggering erroneously.
- If testing building installations or activating devices from third-party companies, you must collaborate with the people appointed.
- The activation of fire control installations for test purposes must not cause injury to anyone or damage to the building installations. The following instructions must be observed:
  - Use the correct potential for activation; this is generally the potential of the building installation.
  - Only check controls up to the interface (relay with blocking option).
  - Make sure that only the controls to be tested are activated.
- Inform people before testing the alarm devices and allow for possible panic responses.
- Inform people about any noise or mist which may be produced.
- Before testing the remote transmission, inform the corresponding alarm and fault signal receiving stations.

### Modifications to the system design and the products

Modifications to the system and to individual products may lead to faults, malfunctioning and safety risks. Written confirmation must be obtained from Siemens and the corresponding safety bodies for modifications or additions.

### Modules and spare parts

- Components and spare parts must comply with the technical specifications defined by Siemens. Only use products specified or recommended by Siemens.
- Only use fuses with the specified fuse characteristics.
- Wrong battery types and improper battery changing lead to a risk of explosion. Only use the same battery type or an equivalent battery type recommended by Siemens.
- Batteries must be disposed of in an environmentally friendly manner. Observe national guidelines and regulations.

### Disregard of the safety regulations

Before they are delivered, Siemens products are tested to ensure they function correctly when used properly. Siemens disclaims all liability for damage or injuries caused by the incorrect application of the instructions or the disregard of danger warnings contained in the documentation. This applies in particular to the following damage:



- Personal injuries or damage to property caused by improper use and incorrect application
- Personal injuries or damage to property caused by disregarding safety instructions in the documentation or on the product
- Personal injury or damage to property caused by poor maintenance or lack of maintenance

## 2.3 Standards and directives complied with

A list of the standards and directives complied with is available from your Siemens contact.

## 2.4 Release Notes

Limitations to the configuration or use of devices in a fire detection installation with a particular firmware version are possible.

	 <b>WARNING</b>
	<p><b>Limited or non-existent fire detection</b></p> <p>Personal injury and damage to property in the event of a fire.</p> <ul style="list-style-type: none"> <li>• Read the 'Release Notes' before you plan and/or configure a fire detection installation.</li> <li>• Read the 'Release Notes' before you carry out a firmware update to a fire detection installation.</li> </ul>

	<b>NOTICE</b>
	<p><b>Incorrect planning and/or configuration</b></p> <p>Important standards and specifications are not satisfied. Fire detection installation is not accepted for commissioning. Additional expense resulting from necessary new planning and/or configuration.</p> <ul style="list-style-type: none"> <li>• Read the 'Release Notes' before you plan and/or configure a fire detection installation.</li> <li>• Read the 'Release Notes' before you carry out a firmware update to a fire detection installation.</li> </ul>

## 3 Structure and function

### 3.1 Overview

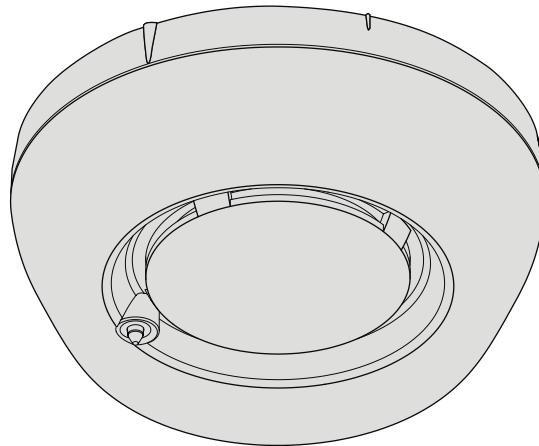

*View of the FDS221*

The alarm sounder FDS221 serves to provide an acoustic alarm in an addressed fire detection system FS20/FS720.

The loud sound of the alarm sounder can be clearly heard as a danger signal when a fire alarm sounds.

Eleven tones are programmed in the alarm sounder. Two tones can be activated for different events (e.g. alarm and evacuation).

The alarm sounder is available in various colors:

- FDS221-R with red hood
- FDS221-W with white hood

#### Features

- Addressed in FDnet/C-NET
- Communication with the control panel via the detector line
- Supply via detector line
- Compatible with
  - Addressable detector base FDB221/FDB221-AA
  - Flat, addressable detector base FDB222
  - Base attachment FDB291
  - Base attachment humid FDB293
- Integrated line separation function
- Self test function
- Sounds are synchronized with all alarm sounders and sounder bases FDSB291 on the same detector line (product version  $\geq 30$  and higher)

### 3.1.1 Details for ordering

Type	Order no.	Designation
FDS221-R	A5Q00004117	Alarm sounder red
FDS221-W	A5Q00006711	Alarm sounder white

### 3.1.2 Product version ES

The product version ES provides the technical status of a device in terms of software and hardware. The product version is provided as a two-digit number.

You will find the details of your device's product version:

- On the packaging label
- On the product label or the type plate

#### Product version on the packaging label

Details of the product version can be found directly on the packaging label in the barcode:

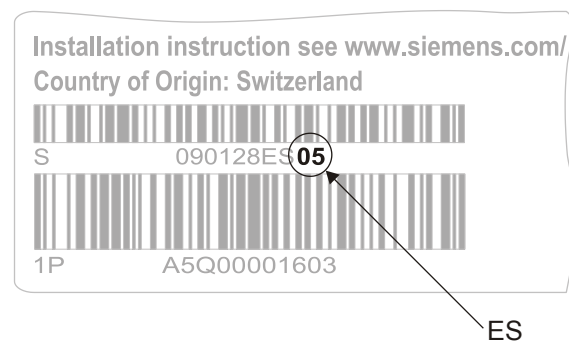

*Example of a packaging label with details of the product version*

#### Product version on the product label and the type plate

Details of the product version can be found after the device order number:

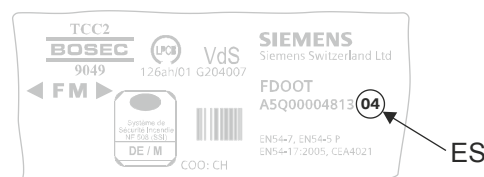

*Example of a product label with details of the product version*



Depending on the product and various approvals, the product labels may differ in terms of the information type and layout.

Look for your device's order number on the product label.

You will find the product version after the order number.



## 3.2 Function

### 3.2.1 Escalation levels and sound levels

The device can be activated for the following selectable escalation levels:

- Warning (Alert)
- Evacuation (EVAC)

The tone can be configured individually for the two selectable escalation levels and the sound level can be configured by device. Different tones are available, each with three sound levels.

#### See also

- 📄 Alarm sounder with ES <30 [→ 26]
- 📄 Alarm sounder with ES ≥30 [→ 27]

### 3.2.2 Line separator

All FDnet/C-NET devices are equipped with a line separator.

The FDnet/C-NET device is equipped with electronic switches which isolate the defective part in case of a short-circuit on the FDnet/C-NET detector line. The rest of the detector line remains serviceable. On a loop line all FDnet/C-NET devices remain fully functional after a simple error.

### 3.2.3 Interface to service devices

A proximity interface (MC link) is available for commissioning and maintenance in order to communicate with the detector exchanger and tester FDUD292 and the intelligent detector tester FDUD293.

You will find more information in documents 007227 and 009718.



---

Status queries with detector exchanger and tester FDUD292 or intelligent detector tester FDUD293 are only possible with devices of the 'Sinteso' product line on the FDnet.

---

### 3.2.4 Diagnosis levels

The device largely monitors its function by itself. The following diagnosis levels are taken from the different control measuring processes:

- Normal
- Fault

For details, see table below.

When a fatal error occurs, which impairs the proper function of the alarm sounder, a fault message is signaled.

To correct the cause of the fault, additional information is available in the device. The additional information can be displayed using e.g. the detector exchanger and tester FDUD292 or the intelligent detector tester FDUD293.

You will find more information in documents 007227 and 009718.

Display	Meaning	Measures
'no deviation'	Normal, no fault is present The alarm sounder is fully functional	None
Any fault message	Fault present <ul style="list-style-type: none"> <li>● Invalid parameter settings</li> <li>● Alarm function no longer ensured (Piezo element defective)</li> </ul>	<ul style="list-style-type: none"> <li>● Set valid parameters</li> <li>● Replace alarm sounder</li> </ul>
	Supply error	<ul style="list-style-type: none"> <li>● Check detector line voltage</li> <li>● Exchange device</li> </ul>
	Software error (Watchdog error)	Exchange device
	Memory error	Exchange device
	Communication error involving device and control panel	Remedy cause



The status 'Any fault message' can be displayed together with another status, e.g. 'needed excha.' (replacement necessary).

### 3.2.5 Behaviour in degraded mode

#### Applicable for the FDnet/C-NET:

When the main processor of the fire control panel fails, the control panel is in degraded mode operation. Depending on the control panel type, the fire control panel can continue to perform the most important alarming and signaling functions in degraded mode operation.

Alarm sounders with product version  $\geq 30$  are also activated and deactivated in case of a fire alarm in degraded mode.

Degraded mode operation on the FDnet/C-NET is not supported in the same way by all control panels. The information in the 'List of compatibility' and in the corresponding control panel documentation must be taken into account during project planning.

## 3.3 Accessories

### 3.3.1 Addressable detector base FDB221/FDB221-AA

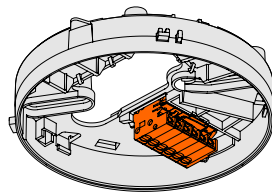

- For the installation of point detectors and alarm sounders
- For the recess-mounted cable entry
- For surface-mounted cable entry, up to 6 mm cable diameter
- Orange terminal block
- Detector base FDB221-AA additionally with a micro terminal
- Compatible with:
  - Point detectors from the 'Sinteso' product line, not with 'Sinteso' in 'collective' mode
  - Alarm sounder FDS221
  - Alarm sounder with additional optical indicator FDS229
  - Sounder interbase FDSB221
  - Sounder interbase with additional optical indicator FDSB229
- Order no. FDB221: A5Q00001664
- Order no. FDB221-AA: A5Q00012741

### 3.3.2 Flat, addressable detector base FDB222

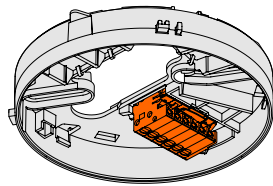

- For the installation of point detectors and alarm sounders
- For the recess-mounted cable entry
- Directly attached to the mounting surface
- Orange terminal block
- Compatible with:
  - Point detectors from the 'Sinteso' product line, not with 'Sinteso' in 'collective' mode
  - Alarm sounder FDS221
  - Alarm sounder with additional optical indicator FDS229
  - Sounder interbase FDSB221
  - Sounder interbase with additional optical indicator FDSB229
- Order no.: S54319-F1-A1

### 3.3.3 Sealing kit FDBZ295

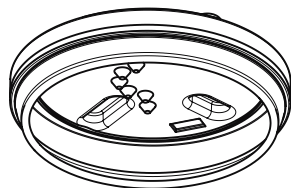

- To protect an alarm sounder or point detector against dirt and splash water
- Cannot be used in conjunction with designation plate FDBZ291
- A detector base FDB2x1 or FDB2x1-AA must be used in addition to the alarm sounder or point detector
- Compatible with:
  - Point detectors from the 'Sinteso' product line
  - Alarm sounder FDS221
  - Alarm sounder with additional optical indicator FDS229
- Order no.: S54319-F10-A1

#### See also

📄 Sealing kit FDBZ295 [→ 32]

### 3.3.4 Base attachment FDB291

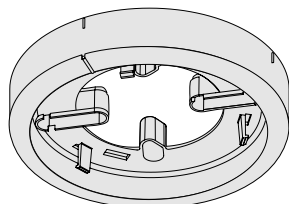

- For the surface-mounted cable entry, as of 6 mm cable diameter
- Compatible with:
  - Detector base FDB2x1/FDB2x1-AA
  - Flat detector base FDB2x2
- Order no.: A5Q00001603

#### See also

📄 Base attachment FDB291 [→ 30]

### 3.3.5 Base attachment humid FDB293

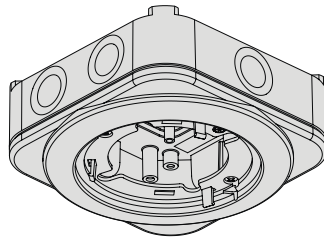

- For installation in humid, wet environments and if the detector heating unit is used
- Protection category achievable: IP54
- Six break-out points for M20 x 1.5 metal cable glands
- Compatible with:
  - Detector base FDB2x1/FDB2x1-AA
  - Flat detector base FDB2x2
  - Detector heating unit FDBH291
  - Designation plate DBZ1 193A
  - M20 x 1.5 metal cable gland
- Order no.: A5Q00003945

**See also**

📄 Base attachment humid FDB293 [→ 31]

### 3.3.6 Base attachment wet FDB295

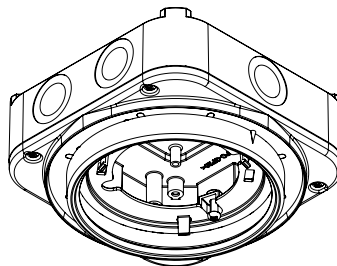

- For installation in humid, wet environments and if the detector heating unit is used
- Protection category achievable: IPxx
- Six break-out points for M20 x 1.5 metal cable glands
- Compatible with:
  - Detector base FDB201/FDB221
  - Flat detector base FDB222
  - Detector heating unit FDBH291
  - Designation plate DBZ1 193A
  - M20 x 1.5 metal cable gland
- Order no.: S54319-F21-A1

### 3.3.7 Protective cage DBZ1194

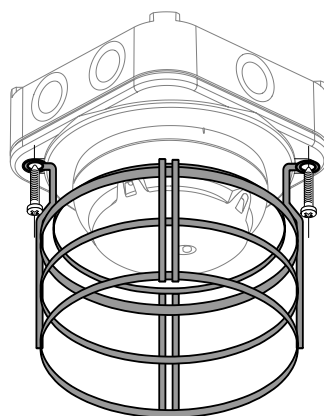

- To protect the devices against mechanical damage
- Can only be used in conjunction with the following accessories:
  - Base attachment humid FDB293
  - Base attachment wet FDB295
  - Base attachment wet BA721
- Order no.: BPZ:4677110001

### 3.3.8 Dummy detector FDX291

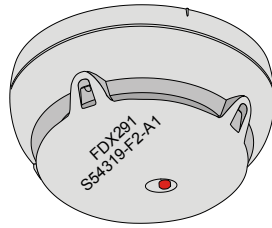

- To protect the detector base from dirt
- External labelling for identification
- Does not open the contact in the detector base
- Compatible with:
  - Detector base FDB2xx
  - Sounder base FDSB29x
- Order no.: S54319-F2-A1

### 3.3.9 Designation plate FDBZ291

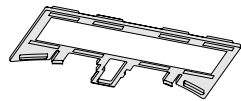

- To identify the location
- Compatible with:
  - Detector base FDB2xx/-AA
  - Detector base FDB271
  - Sounder base FDSB29x
  - Base attachment FDB291
- Order no.: A5Q00002621

#### See also

 Designation plate FDBZ291 [→ 34]

### 3.3.10 Designation plate DBZ1193A

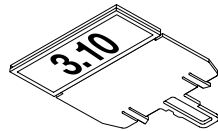

- To identify the location
- Compatible with:
  - Base attachment humid FDB293
  - Base attachment wet FDB295/BA721
  - Base attachment, surface-mounted, humid DBZ1192
  - DBW1171 base
  - Sounder interbase DBS721
  - Sounder interbase with additional optical indicator DBS729
- Order no.: BPZ:4864330001

#### See also

 Designation plate DBZ1193A [→ 35]

### 3.3.11 Detector locking device FDBZ293

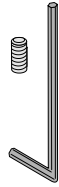

- For protection against theft
- Compatible with:
  - Point detectors from the 'Sinteso' product line
  - Alarm sounder FDS221
  - Alarm sounder with additional optical indicator FDS229
  - Sounder interbase FDSB221
  - Sounder interbase with additional optical indicator FDSB229
- Order no.: A5Q00005035

#### See also

📄 [Detector locking device FDBZ293](#) [→ 36]

### 3.3.12 Micro terminal DBZ1190-AA

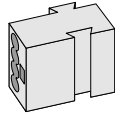

- Auxiliary terminal for connecting cables
- For T-branches of additional cabling e.g. for detector heating units, sounder base, external alarm indicators etc.
- For wire diameters of 0.28...0.5 mm<sup>2</sup>
- 4-pin
- Order no.: BPZ:4677080001

### 3.3.13 Connection terminal DBZ1190-AB

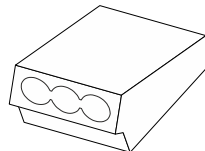

- Auxiliary terminal for connecting cables
- For T-branches of additional cabling e.g. for cable shielding, detector heating units, sounder base, external alarm indicators etc.
- For wire diameters of 1...2.5 mm<sup>2</sup>
- 3 poles
- Order no.: BPZ:4942340001

### 3.3.14 M20 x 1.5 metal cable gland

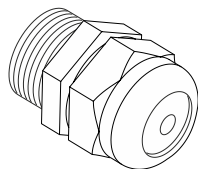

- For introducing a cable into a housing
- For cable diameters of 3.5...5.5 mm
- Temperature range: -40...+100 °C
- Allows for increased IP protection
- Compatible with:
  - M20 x 1.5 metal counter nut
  - Housing FDMH231-S-R
  - Housing FDMH292-x
  - Housing FDMH293-x
  - Housing FDMH297-R
  - Housing FDCH221
- Order no.: A5Q00004478

## 4 Project engineering

Please always take the country-specific provisions and the alarm organization for project planning into account. In addition, the connection factors stated in the specifications must also be taken into account.

### See also

 [Technical data \[→ 39\]](#)

### 4.1 Compatibility

The device is compatible with the following control panels:

- FDnet: all FC20xx control panels
- C-NET: all FC72x control panels

For details, see 'List of compatibility'.

The table below shows the compatibility of the device with various control panels:

Detector line	Control panel			
	FC20xx	FC72x	SIGMASYS	AlgoRex
FDnet	X	–	–	–
C-NET	–	X	–	–

X = compatible

– = not compatible

### 4.2 Ranges of application

The device can be used along escape routes, such as

- Corridor
- Staircases
- Offices
- Warehouses
- Production halls



### 4.3 Installation site

The alarm sounder FDS221 can be mounted directly on the ceiling or the wall.

The device must be easily accessible for commissioning and maintenance so that it can communicate with the detector exchanger and tester FDUD292 or the intelligent detector tester FDUD293 via the interface (MC link).

You will find more information in documents 007227 and 009718.



Status queries with detector exchanger and tester FDUD292 or intelligent detector tester FDUD293 are only possible with devices of the 'Sinteso' product line on the FDnet.

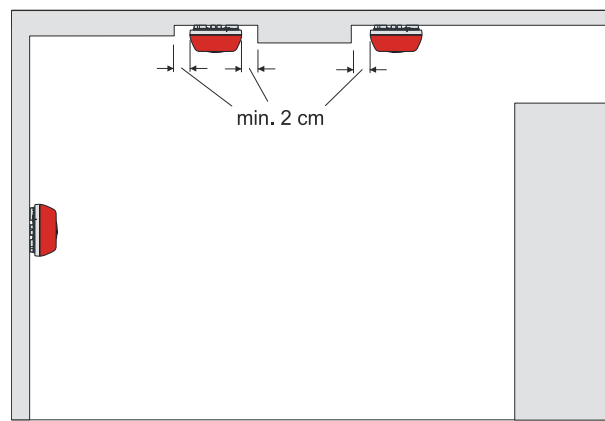

*Installation of the alarm sounder on the wall or ceiling*

### 4.4 Restrictions







- Not compatible with the sounder base FDSB29x
- Devices with a product version <30 cannot be synchronized with the sounder base FDSB291
- Synchronization with the sounder base FDSB291 and with other alarm sounders is only possible for devices with a product version ES  $\geq$ 30.

### 4.5 Configuration

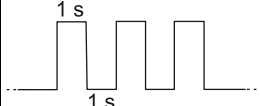
The following chapters contain the specifications of the different tonalities. The specifications differ for alarm sounders with product version ES <30 and product version ES  $\geq$ 30.

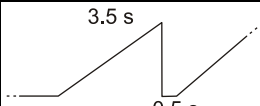
The product version (ES) is specified on the packaging label and on the device label.

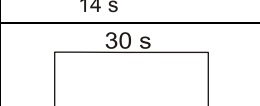
## 4.5.1 Alarm sounder with ES &lt;30

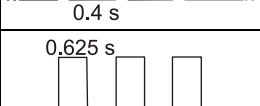
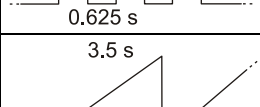
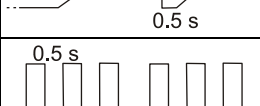
No.	Tone	Frequency pattern Sweep from → to	Pulse pattern	Adjustable sound levels (typ. values in [dBA/1 m] <sup>1</sup> )		Norm
				at 12 V	at 32 V	
1	Continuous	970 Hz		97 87 80	100 91 81	'evacuate' BS 5839 Part 1 1988
2	Intermittent	950 Hz		96 87 79	100 91 81	'alert' BS 5839 Part 1 1988
3	Sweep-down	1,200 Hz → 500 Hz		96 87 79	100 91 80	DIN tone DIN 33404 Part 3
4	Slow-whoop Sweep-up, linear	500 Hz → 1,200 Hz		97 88 81	101 92 82	NEN 2575 (Netherlands)
5	Pulse tone	500 Hz		94 85 77	97 88 77	Swedish Standard SS 03 17 11, No. 1 'Imminent Danger'
6	Intermittent	500 Hz		93 84 75	96 87 75	Swedish Standard SS 03 17 11, No. 3 'Important Message'
7	Continuous	500 Hz		94 85 78	97 88 78	Swedish Standard SS 03 17 11, No. 4 'All clear'
8	Alternating	560 Hz 440 Hz		94 85 77	98 89 76	'French fire sound' NF S 32-001 -1975
9	Intermittent	420 Hz		92 83 75	96 87 78	Australia 'Alert' AS 2220-1978
10	Slow-whoop Sweep-up, linear	500 Hz → 1,200 Hz		96 87 80	100 91 80	Australia 'Action' AS 2220-1978
11	Intermittent	970 Hz		97 87 80	100 90 81	ISO 8201 US Temporal Tone LF

<sup>1</sup> Details of sound level ±2 dBA

The sound level depends on the angle. See 'Technical data annex'

## 4.5.2 Alarm sounder with ES $\geq 30$

No.	Tone	Frequency pattern Sweep from → to	Pulse pattern	Adjustable sound levels (typ. values in [dBA/1 m] <sup>1</sup> )		Norm
				at 12 V	at 32 V	
1	Continuous	970 Hz		98 88 81	101 92 82	'evacuate' BS 5839 Part 1 1988
2	Intermittent	950 Hz		96 87 79	100 91 81	'alert' BS 5839 Part 1 1988
3	Sweep-down	1,200 Hz → 500 Hz		96 87 79	100 91 80	DIN tone DIN 33404 Part 3
4	Slow-whoop Sweep-up, linear	500 Hz → 1,200 Hz		97 88 81	101 92 82	NEN 2575 (Netherlands)
5	Pulse tone	500 Hz		94 85 75	97 88 75	Swedish Standard SS 03 17 11, No. 1 'Imminent Danger'
6	Intermittent	500 Hz		93 84 75	96 87 75	Swedish Standard SS 03 17 11, No. 6 'Local Warning'
7	Continuous	500 Hz		94 85 76	97 88 76	Swedish Standard SS 03 17 11, No. 4 'All clear'
8	Alternating	560 Hz 440 Hz		94 85 75	98 89 76	'French fire sound' NF S 32-001 -1975
9	Intermittent	420 Hz		94 85 76	98 89 77	Australia 'Alert' AS 2220-1978
10	Slow-whoop Sweep-up, linear	500 Hz → 1,200 Hz		96 89 81	100 93 82	Australia 'Action' AS 2220-1978
11	Intermittent	970 Hz		99 89 82	102 92 83	ISO 8201 US Temporal Tone LF

<sup>1</sup> Details of sound level -0 / +4 dBA

The sound level depends on the angle. See 'Technical data annex'

## 5 Mounting / Installation

The alarm sounder FDS221 requires an addressed detector base. The detector base is mounted on the wall or on the ceiling.

The device must be easily accessible for commissioning and maintenance so that it can communicate with the detector exchanger and tester FDUD292 or the intelligent detector tester FDUD293 via the interface (MC link).



---

The alarm sounder FDS221 cannot be used or removed with the detector exchanger and tester FDUD292 or the intelligent detector tester FDUD293!

---

Proceed as follows when installing:

1. Install a detector base.
  - For recess-mounted cable entry: Flat, addressable detector base FDB222
  - For surface-mounted cable entry and cable diameter  $\leq 6$  mm: Addressable detector base FDB221 or FDB221-AA
  - For surface-mounted cable entry and cable diameter  $> 6$  mm: Base attachment FDB291 and addressable detector base FDB221 or FDB221-AA
  - For applications in wet rooms: Base attachment humid FDB293 and flat, addressable detector base FDB222 or base attachment humid FDB293 and addressable detector base FDB221/FDB221-AA
2. Place the alarm sounder FDS221 into the detector base and turn the alarm sounder FDS221 until it snaps in.

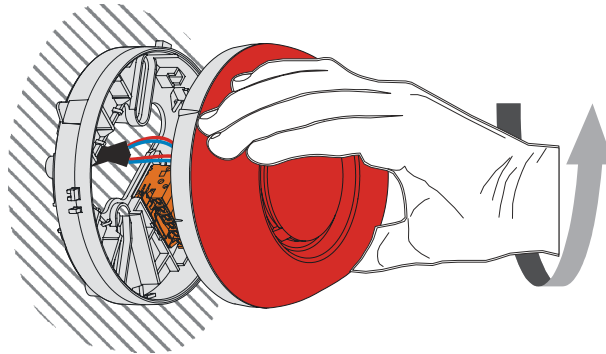

*Wall mounting of FDS221 alarm sounder in an FDB221 detector base*

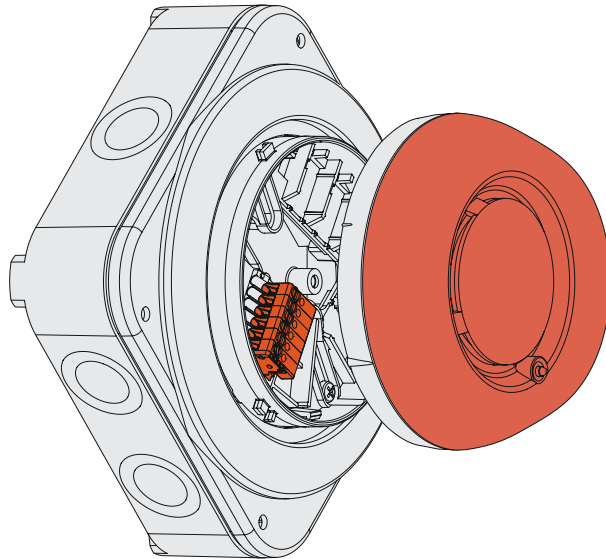

*Wall mounting of FDS221 alarm sounder with a base attachment humid FDB293 and a detector base FDB221*

**See also**

- 📄 Base attachment FDB291 [→ 30]
- 📄 Base attachment humid FDB293 [→ 31]

## 5.1 Base attachment FDB291

▷ Use the base attachment FDB291 for surface-mounted cable entry and cable diameters between 6 mm and 21 mm.

1. Break out the required cable entries on the base attachment FDB291.
2. Insert the cables through the break-outs in the base attachment FDB291.

●

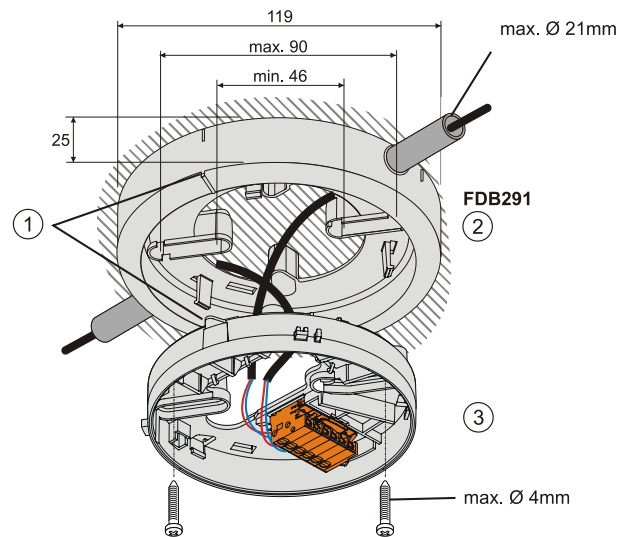

*Installation of detector base on base attachment FDB291*

1 Identification

3 Detector base acc. to  
'Accessories' chapter

2 Base attachment

### See also

- 📄 Addressable detector base FDB221/FDB221-AA [→ 19]
- 📄 Flat, addressable detector base FDB222 [→ 20]

## 5.2 Base attachment humid FDB293

- For installation in wet rooms, the base attachment humid FDB293 is used.
- To seal the cables, especially tight metal cable glands M20 x 1.5 are used.

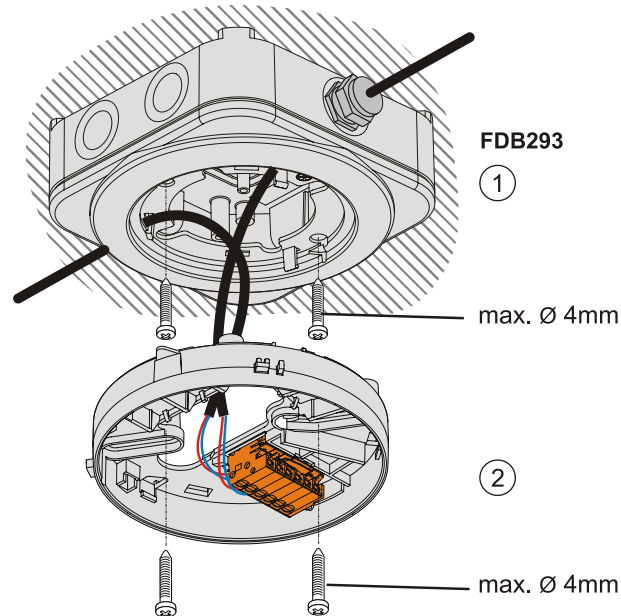

*Installation of detector base on base attachment humid FDB293*

1 Base attachment humid

2 Detector base acc. to  
 'Accessories' chapter

### See also

- 📄 Addressable detector base FDB221/FDB221-AA [→ 19]
- 📄 Flat, addressable detector base FDB222 [→ 20]

### 5.3 Sealing kit FDBZ295

The sealing element FDBZ295 is used in conjunction with detector bases FDB2x1/FDB2x1-AA. The sealing element provides the device with protection against dirt and spray water.

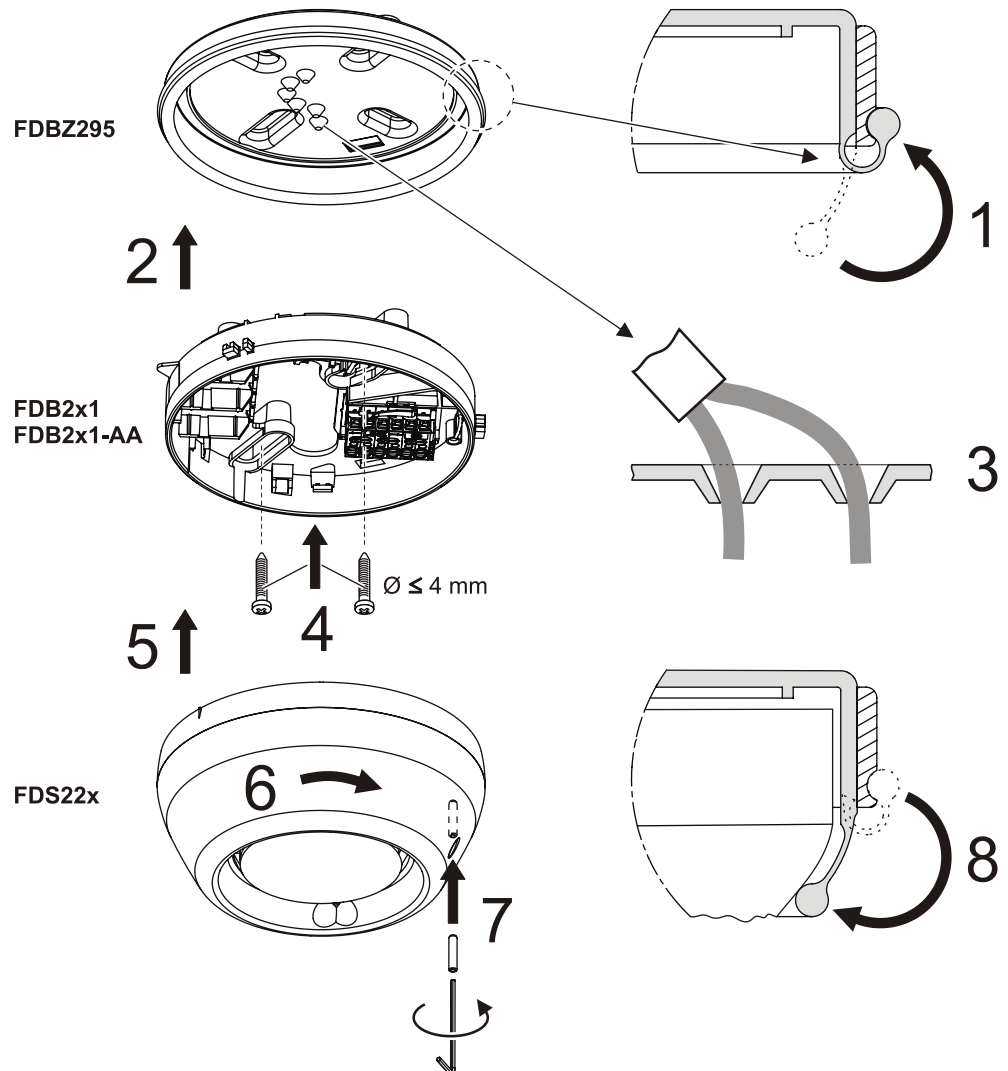

*Installation of sealing kit FDBZ295*



## Installation

- ▷ The kit is installed by hand
- 1. Fold the sealing lip back.
- 2. Insert the detector base into the sealing kit. Make sure that the opening in the detector base lines up with the marking and opening on the rubber base.

<b>!</b>	<b>NOTICE</b>
	<p><b>Risk when piercing the rubber base with a tool!</b></p> <p>Consequences: Leaks in rubber base</p> <ul style="list-style-type: none"> <li>• Do not use tools for piercing!</li> </ul>

- 3. Push the connection wires through the rubber base from the rear.
  - 4. Install the detector base.
  - 5. Place a point detector or alarm sounder in the detector base.
  - 6. Turn the point detector or alarm sounder to the right to screw it firmly into the detector base.
  - 7. Screw the supplied set screw into the point detector or alarm sounder until it no longer protrudes. This step is not needed when using detector locking device FDBZ293.
  - 8. Fold the folded-back sealing lip over the point detector or alarm sounder.
- ⇒ The sealing element is installed.

## 5.4 Designation plate FDBZ291

1. Label designation plate FDBZ291 with location address of point detector or alarm sounder.
2. Note the small mark on the installed point detector or alarm sounder and slide designation plate into detector base or sounder base.

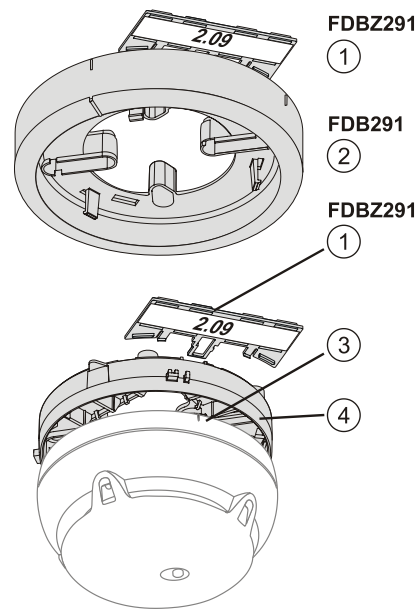

*Installation of designation plate FDBZ291*

1 Designation plate FDBZ291

3 Marks on point detector/alarm sounder

2 Base attachment FDB291

4 Detector base/sounder base

### See also

- 📄 Addressable detector base FDB221/FDB221-AA [→ 19]
- 📄 Flat, addressable detector base FDB222 [→ 20]

## 5.5 Designation plate DBZ1193A

To provide a detector or alarm sounder on a base attachment humid FDB293 with a location address, the detector designation plate DBZ1193A is labelled and placed on the base attachment humid FDB293.

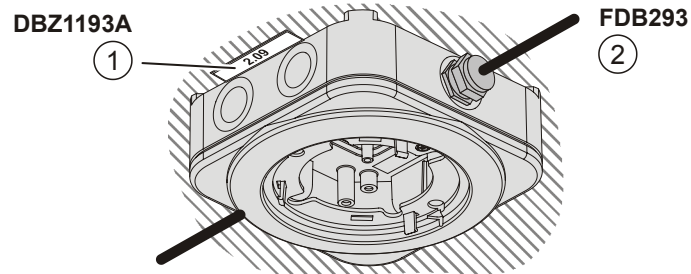

*Installation of designation plate DBZ1193A*

1 Designation plate DBZ1193A

2 Base attachment humid FDB293

## 5.6 Detector locking device FDBZ293

A point detector or alarm sounder can be protected against theft with the detector locking device FDBZ293.

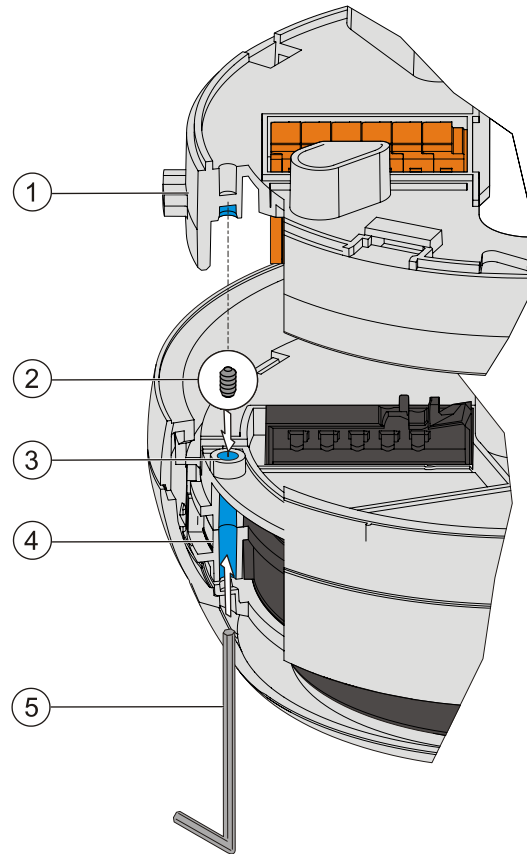

*Installation of detector locking device FDBZ293*

- |                                   |             |
|-----------------------------------|-------------|
| 1 Detector base                   | 4 Detector  |
| 2 Set screw with a hexagon socket | 5 Allen key |
| 3 Hole                            |             |

1. Place the 'set screw with a hexagon socket' (2) in the hole (3) on the detector (4).
  2. Insert the detector (4) into the detector base (1).
  3. Using the Allen key provided (5), insert the 'set screw with a hexagon socket' (2) through the hole in the detector base (1) and tighten.
- ⇒ The detector can no longer be removed from the base without tools.

### See also

- 📄 Addressable detector base FDB221/FDB221-AA [→ 19]
- 📄 Flat, addressable detector base FDB222 [→ 20]

---

## 6 Commissioning

The devices are commissioned via the control panel. The exact procedure is described in the control panel documentation.

Conduct a performance check once commissioning is complete.

## 7 Maintenance / Repair

### 7.1 Status retrieval

The alarm sounder FDS221 has a proximity interface (MC link).

Using this interface, it is possible to read out data from the device in a proximity method over short distances with the detector exchanger and tester FDUD292 or the intelligent detector tester FDUD293.

You will find more information in documents 007227 and 009718.



---

Status queries with detector exchanger and tester FDUD292 or intelligent detector tester FDUD293 are only possible with devices of the 'Sinteso' product line on the FDnet.

---

The following actions can be performed from the control panel:

- Configure sounds
- Commissioning
- Activate / deactivate sound
- Read error list / status register

### 7.2 Function check

The devices are automatically subjected to a performance check during the self-test. Nevertheless, it is necessary to check the devices on site at regular intervals.

**Recommendation:**

- Check the devices every year.
- Replace heavily soiled or damaged devices.

No other special maintenance work is necessary.

You will find more detailed information in the fire detection system documentation.

## 8 Specifications

### 8.1 Technical data

You will find information on approvals, CE marking, and the relevant EU directives for this device (these devices) in the following document(s); see 'Applicable documents' chapter:

- Document 007026

<b>Detector line</b>	Operating voltage	DC 12...33 V
	Operating current:	
	● Standby	250 $\mu$ A
	● Sound activated	3.5 mA
	Maximum current connection factor	15
	Quiescent current connection factor	1
	Address connection factor	1
	Separator connector factor	1
	Communication protocol	FDnet/C-NET
System compatibility	See 'List of compatibility'	
<b>Line separator</b>	Line voltage:	
	● Nominal	DC 32 V (= $V_{nom}$ )
	● Minimum	DC 12 V (= $V_{min}$ )
	● Maximum	DC 33 V (= $V_{max}$ )
	Voltage at which the separator opens:	
	● Minimum	DC 7.5 V (= $V_{SO min}$ )
	● Maximum	DC 10.5 V (= $V_{SO max}$ )
	Permanent current when switches are closed:	Max. 0.5 A (= $I_C max$ )
	Switching current (e.g., in the event of a short-circuit)	Max. 1 A (= $I_S max$ )
	Leakage current when switches are open:	Max. 1 mA (= $I_L max$ )
Serial impedance when switches are closed:	Max. 0.5 $\Omega$ (= $Z_C max$ )	
<b>External alarm indicators</b>	Number of external alarm indicators that can be connected	2
	Voltage	DC 10...17 V
	Current	9...15 mA
	Length of line	<ul style="list-style-type: none"> <li>● Max. 30 m with unshielded cables (recommended), or when the shielding is connected to the positive pole of the AI on the detector base</li> <li>● Max. 5 m, if the shielding is connected to earth</li> </ul>

<b>Function</b>	Number of sounds	11
	Activation levels	2
	Sound level	Depending on the set tone; see chapter 'Configuration' for details
<b>Connections</b>	Detector line:	
	● Design	Plug-type connection
	MC link:	
	● Design	Proximity interface
<b>Ambient conditions</b>	Operating temperature	-25...+70 °C
	Storage temperature	-30...+75 °C
	Air humidity	≤95 % rel.
	Protection categories according to EN 60529/IEC 60529:	
	● Detector base FDB221, FDB222, wall mounting, connection from below	IP43
	● Detector base FDB221, FDB222, all other modes of installation	IP40
	● Detector base FDB221 with sealing element FDBZ295	IP44
	● Base attachment FDB291, wall mounting, connection from below	IP43
	● Base attachment FDB291, all other installation methods	IP40
	● Base attachment humid FDB293	IP54
	Electromagnetic compatibility at:	
● 1 MHz...1 GHz	50 V/m	
● 1 GHz...2 GHz	30 V/m	
<b>Mechanical data</b>	Dimensions (Ø x H)	100 x 43 mm
	Housing material	Polycarbonate (PC)
	Colors	<ul style="list-style-type: none"> <li>● ~RAL 9010 pure white</li> <li>● ~RAL 3000 flame red</li> </ul>
<b>Standards</b>	European standards	<ul style="list-style-type: none"> <li>● EN 54-3</li> <li>● EN 54-17</li> </ul>



## 8.2 Dimensions

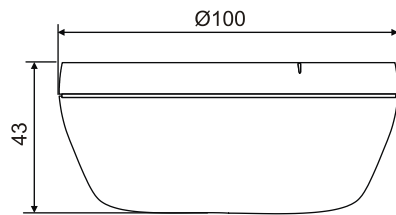

*Dimensions of FDS221 alarm sounder*

## 8.3 Environmental compatibility and disposal



This device is manufactured using materials and procedures which comply with current environmental protection standards as best as possible. More specifically, the following measures have been undertaken:

- Use of reusable materials
- Use of halogen-free plastics
- Electronic parts and synthetic materials can be separated

Larger plastic parts are labeled according to ISO 11469 and ISO 1043. The plastics can be separated and recycled on this basis.



Electronic parts and batteries must not be disposed of with domestic waste.

- Take electronic parts and batteries to local collection points or recycling centers.
- Contact local authorities for more information.
- Observe national requirements for disposing of electronic parts and batteries.

## 9 Annex technical data

### 9.1 Tones and sound levels of the alarm sounder (DC 32 V)

Minimum sound level measured in dBA/1 m (DC 32 V)

#### Tone No. 1: Continuous

Sound level	Horizontal						Vertical					
	15°	45°	75°	105°	135°	165°	15°	45°	75°	105°	135°	165°
0 (max.)	82	88	89	89	88	86	82	88	89	89	88	86
1 (mid.)	72	78	79	79	78	76	72	78	79	79	78	76
2 (low)	62	68	69	69	68	66	62	68	69	69	68	66

#### Tone No. 2: Intermittent

Sound level	Horizontal						Vertical					
	15°	45°	75°	105°	135°	165°	15°	45°	75°	105°	135°	165°
0 (max.)	83	87	91	90	88	87	83	87	91	90	88	87
1 (mid.)	73	77	81	80	78	77	73	77	81	80	78	77
2 (low)	63	67	71	70	68	67	63	67	71	70	68	67

#### Tone No. 3: Sweep-down

Sound level	Horizontal						Vertical					
	15°	45°	75°	105°	135°	165°	15°	45°	75°	105°	135°	165°
0 (max.)	86	89	93	93	90	88	86	89	93	93	90	88
1 (mid.)	76	79	83	83	80	78	76	79	83	83	80	78
2 (low)	66	69	73	73	70	68	66	69	73	73	70	68

#### Tone No. 4: Slow-whoop Sweep-up, linear

Sound level	Horizontal						Vertical					
	15°	45°	75°	105°	135°	165°	15°	45°	75°	105°	135°	165°
0 (max.)	89	91	94	93	91	89	89	91	94	93	91	89
1 (mid.)	79	81	84	83	81	79	79	81	84	83	81	79
2 (low)	69	71	74	73	71	69	69	71	74	73	71	69

**Tone No. 5: Pulse tone**

Sound level	Horizontal						Vertical					
	15°	45°	75°	105°	135°	165°	15°	45°	75°	105°	135°	165°
0 (max.)	83	87	89	90	86	82	84	87	89	90	86	82
1 (mid.)	73	77	79	80	76	72	74	77	79	80	76	72
2 (low)	63	67	69	70	66	62	64	67	69	70	66	62

**Tone No. 6: Intermittent**

Sound level	Horizontal						Vertical					
	15°	45°	75°	105°	135°	165°	15°	45°	75°	105°	135°	165°
0 (max.)	84	85	85	88	84	81	84	85	85	88	84	81
1 (mid.)	74	75	75	78	74	71	74	75	75	78	74	71
2 (low)	64	65	65	68	64	61	64	65	65	68	64	61

**Tone No. 7: Continuous**

Sound level	Horizontal						Vertical					
	15°	45°	75°	105°	135°	165°	15°	45°	75°	105°	135°	165°
0 (max.)	83	85	88	88	85	83	83	85	88	88	85	83
1 (mid.)	73	75	78	78	75	73	73	75	78	78	75	73
2 (low)	63	65	68	68	65	63	63	65	68	68	65	63

**Tone No. 8: Alternating**

Sound level	Horizontal						Vertical					
	15°	45°	75°	105°	135°	165°	15°	45°	75°	105°	135°	165°
0 (max.)	87	90	91	91	89	85	87	90	91	91	89	85
1 (mid.)	77	80	81	81	79	75	77	80	81	81	79	75
2 (low)	67	70	71	71	69	65	67	70	71	71	69	65

**Tone No. 9: Intermittent**

Sound level	Horizontal						Vertical					
	15°	45°	75°	105°	135°	165°	15°	45°	75°	105°	135°	165°
0 (max.)	80	85	88	86	82	81	80	85	88	86	82	81
1 (mid.)	70	75	78	76	72	71	70	75	78	76	72	71
2 (low)	60	65	68	66	62	61	60	65	68	66	62	61

**Tone No. 10: Slow-whoop Sweep-up, linear**

Sound level	Horizontal						Vertical					
	15°	45°	75°	105°	135°	165°	15°	45°	75°	105°	135°	165°
0 (max.)	88	91	94	94	92	91	88	91	94	94	92	91
1 (mid.)	78	81	84	84	82	81	78	81	84	84	82	81
2 (low)	68	71	74	74	72	71	68	71	74	74	72	71

**Tone No. 11: Intermittent**

Sound level	Horizontal						Vertical					
	15°	45°	75°	105°	135°	165°	15°	45°	75°	105°	135°	165°
0 (max.)	82	83	90	93	84	86	82	83	90	93	84	86
1 (mid.)	72	73	80	83	74	76	72	73	80	83	74	76
2 (low)	62	63	70	73	64	66	62	63	70	73	64	66

# Index

## A

### Alarm sounder

- with ES <30, 26
- with ES ≥30, 27

### Approvals, 39

## C

### CE marking, 39

### Compatibility

- with control panels, 24
- with sounder base FDSB29x, 25

### Control panel, 37

## D

### Degraded mode operation

- Fire control panel failure, 19

### Detector exchanger and tester FDUD292

- MC link, 17, 38

### Diagnosis levels, 18

### Disposal, 41

### Documentation for fire detection system, 7

### Download center

- URL, 7

## E

### Environmental compatibility, 41

## ES

- Product version, 16, 25

### Escalation levels, 17

### EU directives, 39

## F

### Faults

- Error, 18

### Fire control panel failure

- Degraded mode operation, 19

## I

### Intelligent detector tester FDUD293

- MC link, 17, 38

### Interface

- MC link, 38

## L

### Line separator

- Function, 17

### List of compatibility, 7, 19, 24

## M

### Maintenance intervals, 38

### MC link, 38

- Detector exchanger and tester FDUD292, 17, 38
- Intelligent detector tester FDUD293, 17, 38
- Proximity interface, 17

## P

### Packaging label

- Product version, 16

### Product label

- Product version, 16

### Proximity interface

- MC link, 17

## R

### Recycling, 41

## S

### Short-circuit

- Line separator, 17

### Sound level, 17

### Standards, 40

## T

### Type plate

- Product version, 16

Issued by  
Siemens Switzerland Ltd  
Infrastructure & Cities Sector  
Building Technologies Division  
International Headquarters  
Gubelstrasse 22  
CH-6301 Zug  
Tel. +41 41-724 24 24  
[www.siemens.com/buildingtechnologies](http://www.siemens.com/buildingtechnologies)

© 2004-2013 Copyright Siemens Switzerland Ltd  
Technical specifications and availability subject to change without notice.